

M40 X-TREME



CONTENTS

BLINDER M40 X-TREME
comes complete with
Mounting outline
Mounting guide
Electrical guide
Police laser guns
Product registration
Warranty service
Consumer warranty
BLINDER worldwide service

2 Thank you for buying the BLINDER M40
3 X-TREME LASERJAMMER. When
4 mounted correctly, the BLINDER M40
5 X-TREME LASERJAMMER will
6 effectively protect you against the police
6 laser speed control.
7
7 Please read this installation guide
7 carefully before installation.
7 We strongly recommend that a profes-
7 sional install your BLINDER M40
7 X-TREME.

BLINDER M40 X-TREME LASERJAMMER

BLINDER M40 X-TREME comes complete with

- 4 pcs. Jammer / detector transceivers
- Interface box
- Electrical wire with laser alert LED, Audible Beeper alert and output to auto-mute
- Mounting bracket for the LED
- On / off switch
- Electrical wires for connecting on / off switch to power supply 12 volt.
- Spirit level for correct installing of the transceivers
- 1 pcs. Mounting fittings including
- 8 brackets for mounting
- 16 screws for mounting the brackets on the transceivers
- 16 screws for mounting the brackets on the car
- 16 washers for mounting the brackets on the car
- Product registration card

1 Start with mounting the 4 transceivers in the front of the car. Route the cables to the car's interior for connection to the interface box.

2 Locate a suitable place for the interface box inside the car's interior. The interface box must not be mounted in the engine compartment because of moisture. The 4 cables from the transceivers are plugged into the jacks indicated by the numbers 1 to 4.

3 Locate a suitable place for the buzzer laser alert and the warning/power on LED. The cable is plugged into the jacks on the interface box marked "alert".

4 The red wire (+) from the interface box is connected to the on / off switch. The on / off switch is then connected by the extension cable to a switched 12-volt power supply.

5 The black wire from the interface box is connected to ground (-).

6 The blue wire from the interface box can be connected to the auto mute on the car-stereo (see the car-stereo manual).

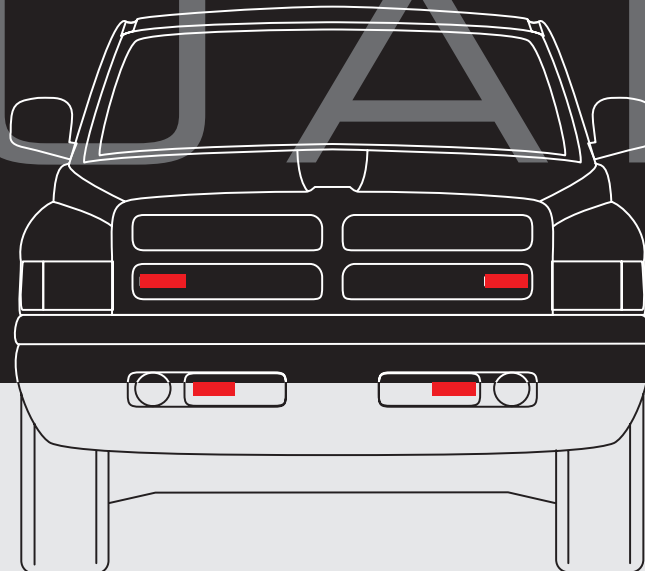

1 Mounting the transceivers

It's very important that the transceivers are mounted correctly:

- ▶ Since the infrared laser beam from the speed laser gun and the infra red return signal from the transceivers will not pass through any objects, it is essential that the transceivers have an unobstructed view of the road ahead.
- ▶ The transceivers must point straight ahead and not follow the curve on the front of the car and must be horizontal to the road surface and parallel to the driving direction.

1.1 Determine the best location for the 4 laser transceivers. For optimum performance, install one transceiver on either side of the front license plate

with a distance between the two of 50 – 60 cm. Install the two other transceivers higher and close to the headlights (please see the figure on the top of this page).

- 1.2 Fit the mounting brackets on each transceiver using the screws.
- 1.3 Mount the transceivers making sure that each transceiver is level to the road and parallel to the driving direction.

1.4 Use the enclosed spirit level to adjust the horizontal angle for the two transceivers. On the outer side of the front on each transceiver you find a detachable plug. Remove one plug on each transceiver, and put the spirit level into the cylindrical hole.

Now you can carefully adjust the angle of the transceivers to horizontal position. After finishing the adjustment, re-mount the two plugs into the front of each transceiver.

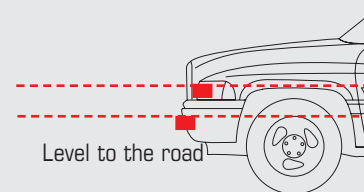
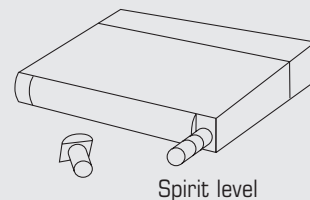

2 Interface Box

Locate a suitable place for the interface box inside the car's interior. The interface box must not be located in the engine compartment because of moisture. The 4 cables from the transceivers are plugged into the jacks indicated by the numbers 1 to 4.

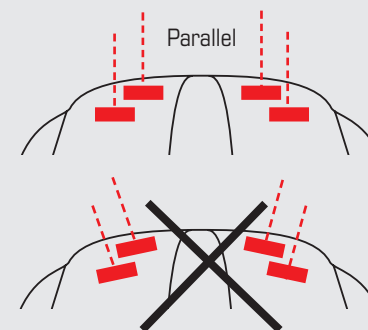

- 1** Transceivers
- 2** Interface
- 3** Laser alert
- 4** Audio mute (blue)
- 5** Ground (black)
- 6** 12V. Ignition power (red)

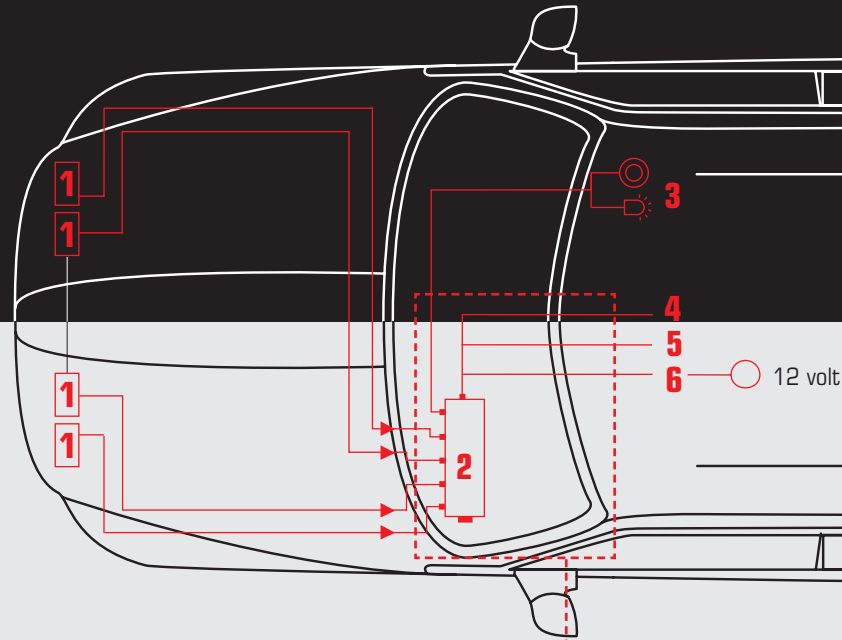

3 Laser alerts

Locate a suitable place for the buzzer laser alert and the warning/power on LED. The cable is plugged into the jacks on the interface box marked "alert". The LED will light green when power is on and red when the car is hit by a speed laser gun. The laser jamming starts automatically and continues until the speed laser gun is turned off.

4 Connection to audio mute

The blue wire from the interface box can be connected to the audio mute on the car-stereo (see the car-stereo manual).

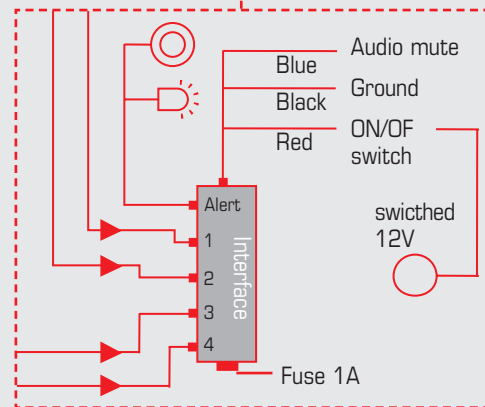

5 Connection to ground

The black wire from the interface box is connected to ground (-).

6 Connection to power supply

The red wire (+) from the interface box is connected to the on / off switch. The on / off switch is then connected by the extension cable to a switched 12-volt power supply.

DEALING WITH POLICE LASER GUNS

To avoid any problems with the police, we strongly recommend following the method mentioned below when dealing with police laser guns:

As soon as you hear the BLINDER laser warning signal, you must immediately

1. Slow down to legal speed limits
2. Switch off the BLINDER

In that way you will allow the police to get a clear speed measurement without attracting any attention. Often the police need two or three shoots before getting a valid speed measurement. Therefore turn off the BLINDER within a few seconds, and no one will suspect that a laser jammer is being used!

PRODUCT REGISTRATION

Please fill in and send the enclosed Product Registration Form. By sending this registration form, we can offer on-line technical help and other support on the Internet.

ONLINE REGISTRATION

You are welcome to register your BLINDER Laserjammer on the Internet. Go to: www.blinder.dk

WARNING!

Do not look directly into the BLINDER X-TREME with the naked eye at close range. You won't see anything, but you might cause eye damage after prolonged exposure. Remember, the BLINDER X-TREME emits infrared (IR) light, which is not visible to the human eye, regardless of how strong it is.

WARNING!

- BLINDER does not advocate exceeding the legal speed limits.
- BLINDER shall not be held responsible for any injuries that could occur due to improper installation or usage of the product.
- Professional installation is recommended.

BLINDER WARRANTY SERVICE

If service is required, please follow the instructions below.

To obtain service during the one-year warranty period, please contact:

BLINDER USA

11000 Prosperity Farms Road
Suite 105
Palm Beach Gardens
FL 33410, USA
Phone: 561-373-3946
Fax: 561-625-4433

sales@blinder.us
www.blinder.us

OTHER COUNTRIES:

BLINDER International
Strandlodsvej 13
DK-2300 Copenhagen S
Denmark
Phone +45 3296 3200
Fax +45 3296 3231

sales@blinder.dk
www.blinder.dk

Shipping your BLINDER for repair or replacement

For your own protection, obtain a proof of delivery receipt. Shipping costs are your responsibility.

Enclose with your unit the following information:

Your name, complete return address and written description of the problem (no P.O. Box please).

A telephone number where you can be reached during business hours.

A copy of your dated sales receipt.

Scratches and stone damage can also affect output. If the lens becomes too badly damaged, order replacement lenses separately. We suggest replacing the lens every 12 months.

When the ignition is turned on, the upstart self-test function will, turn on the interior alert for two seconds telling you that the BLINDER X-TREME is ready to protect you. The warning LED will turn green.

BLINDER Consumer Warranty LIMITED ONE-YEAR WARRANTY

This warranty covers all defects in materials and workmanship. This warranty does not apply if the unit has been subject to physical abuse, improper installation, modification, or if the housing or serial number of the unit has been removed.

BLINDER International manufactures its products using parts and components, which are new or equivalent to new in accordance with industry standard practices.

The enforceability of this warranty is limited to the original consumer purchaser. It is not transferable to, or enforceable by, any subsequent owner.

In the event of a defect, malfunction or other failure to conform to this warranty, BLINDER International will, at its sole discretion, repair or replace the unit at no charge. You are responsible for all shipping costs in connection with warranty service pursuant to this warranty.

This warranty commences on the date of the retail purchase and shall be effective for a period of one year.

There are no express warranties covering the unit other than those set forth in this warranty. All implied warranties are limited to the one-year period of this warranty and no warranties, expressed or implied, extend beyond this one-year period. Some states do not allow limitation on how long an implied warranty lasts, so the above limitation may not apply to you.

BLINDER International will in no event be liable for any consequential, incidental, indirect or special damages (including, but not limited to, lost profits) arising out of or in connection with the use, misuse or function of the unit. Some states do not allow the exclusion of limitation of incidental or consequential damages, so the above limitation or exclusion may not apply to you.

You must provide a copy of a dated receipt for your unit in order to receive service under warranty.

BLINDER WORLDWIDE SERVICE

USA: www.blinder.us
sales@blinder.us

Other: www.blinder.dk
sales@blinder.dk

Service and control

Keep in mind that snow and dirt on the lens decrease the output of the BLINDER X-TREME's range to where it may not detect or jam the police laser gun when you need it. Therefore the lens should be kept clean.



BLINDER International

Strandlodsvej 13

DK-2300 Copenhagen S

Denmark

Phone +45 3296 3200

Fax +45 3296 3231

sales@blinder.dk

www.blinder.dk